

Kemp 20mm

20mm male valve



The Kemp 20mm Valve is a general purpose male valve, which is suitable for a wide range of applications across all key aerosol market segments.

For use with a specific selection of standard and custom actuators.

Product features:

- ✔ Ideal for pharmaceutical applications
- ✔ Continuous or metered dose valve
- ✔ Available metered volumes (25-120 µl)
- ✔ Clean room manufacturing
- ✔ Extensive specification combinations available



More info:

Visit: www.lindalgroup.com

Email: products@lindalgroup.com

Contact: Your local sales consultant



Your Innovation Partner

Kemp 20mm

Technical details
20mm male valve

1 Ferrule

Aluminium Alloy

2 Outer Gasket

Neoprene, Buna, Chlorobutyl, Butyl

3 Inner Gasket

Neoprene, Buna, Chlorobutyl, Butyl

4 Valve stem

Acetal copolymer

- 3.0mm stem \varnothing
- 1 or 2 orifices with 0.4mm \varnothing to 0.6mm \varnothing

5 Metering chamber

TPE

6 Spring

Stainless steel

7 Housing

Acetal copolymer

- Slotted version available for inverted use

8 Diptube

Olefin resin

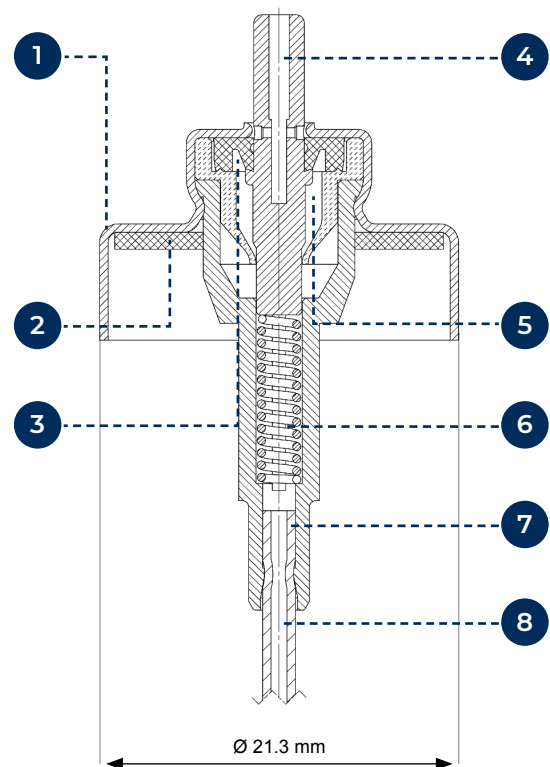

* Dimensions are subject to standard manufacturing tolerances



i Further technical information is available on request

More info:

Visit: www.lindalgroup.com

Email: products@lindalgroup.com

Contact: Your local sales consultant



Your Innovation Partner