

300 Series

Full cup female actuator



A very popular button actuator suitable for applications across personal care, home care, technical and pharmaceutical market segments.

Product features:

- ✔ Available with MBU (mechanical breakup) and non-MBU inserts
- ✔ Compatible with LINDAL's RT valve and female Bag-on-valve (BOV)



More info:

Visit: www.lindalgroup.com

Email: products@lindalgroup.com

Contact: Your local sales consultant



Your Innovation Partner

300 Series

Technical details

Full cup female actuator

Available configurations

- ✔ Compatible with LINDAL's RT valve and female Bag-on-valve (BOV)
- ✔ Available with MBU (mechanical breakup) and non-MBU inserts

Technical details

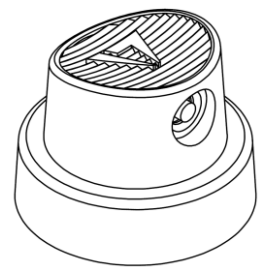
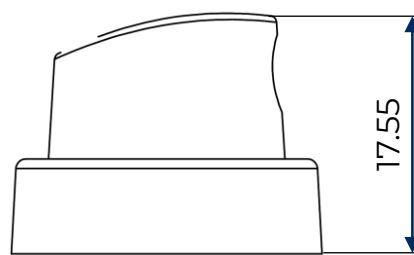
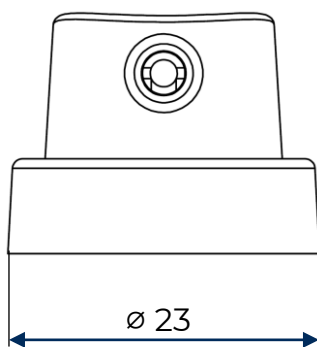

Compatible valves	RT, Female BOV	Suitable cans	Aluminium Tinplate
Stem Ø	N/A	Available overcap	N/A
Available insert	120, 130		
Skirt size	N/A		

i Further technical information is available on request

Product packaging

- ✔ 9,000 units per box
- ✔ 20 boxes per euro pallet
- ✔ 180,000 units per pallet

More info:

Visit: www.lindalgroup.com

Email: products@lindalgroup.com

Contact: Your local sales consultant



Your Innovation Partner