

FL-A

Full cup actuator with overcap



The FL-A actuator is designed specifically for use with fire extinguishers and insecticides.

Product features:

- ✔ Designed for use with fire extinguishers and insecticides
- ✔ Compatible only with LINDAL's FL valve



More info:

Visit: www.lindalgroup.com

Email: products@lindalgroup.com

Contact: Your local sales consultant



Your Innovation Partner

Available configurations

- ✔ Compatible only with LINDAL's FL valve
- ✔ Available with or without FL-A overcap

Technical details

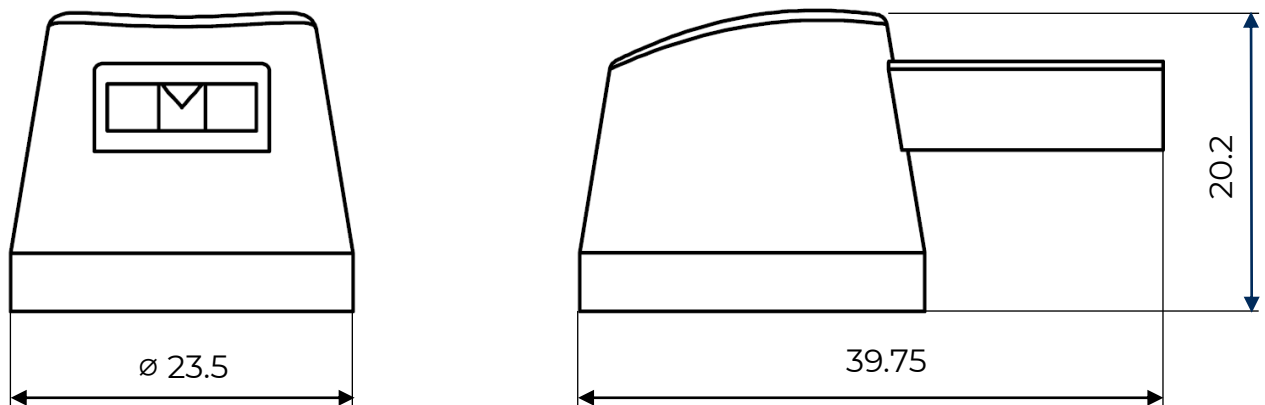

| | | | |
|-------------------|----------|-------------------|-----------------------|
| Compatible valves | FL valve | Suitable cans | Aluminium Tinplate |
| Stem Ø | 4mm | Available overcap | FL-A Overcap |
| Available insert | N/A | | |
| Skirt size | N/A | | |

i Further technical information is available on request

Product packaging

- ✔ 1,500 / 4,500 units per box
- ✔ 20 boxes per euro pallet
- ✔ 30,000 / 90,000 units per pallet

More info:

Visit: www.lindalgroup.com

Email: products@lindalgroup.com

Contact: Your local sales consultant



Your Innovation Partner