

ST838/39/40

Spray head



A spray head actuator designed for applications in the personal care, home care, technical, pharmaceutical and food market segments.

Product features:

- ✔ Matt finish actuator supplied with or without overcap
- ✔ Overcap available in either matt or gloss
- ✔ Foam or Gel versions are available
- ✔ Various skirt heights available
- ✔ Available with MBU (mechanical breakup) and non-MBU inserts
- ✔ Compatible with LINDAL's LI, LIB, and male Bag-on-valve (BOV)



More info:

Visit: www.lindalgroup.com

Email: products@lindalgroup.com

Contact: Your local sales consultant



Your Innovation Partner

ST838/39/40

Technical details
Spray head

Available configurations

- ✔ Spray, foam or gel version available
- ✔ Compatible with LINDAL's LI, LIB, and male Bag-on-valve (BOV)
- ✔ Available with MBU (mechanical breakup) and non-MBU inserts

Technical details

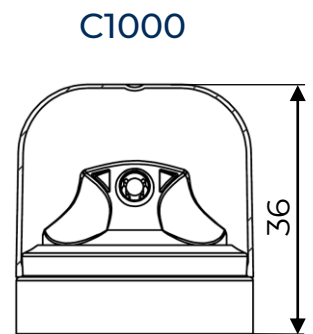
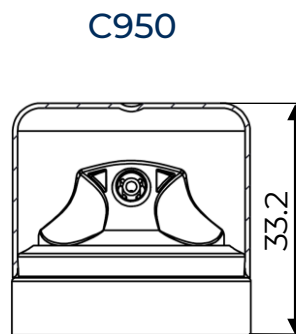
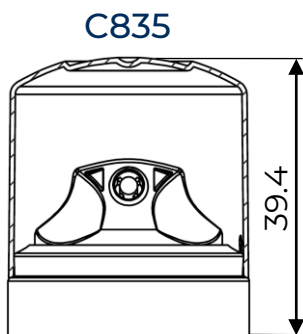
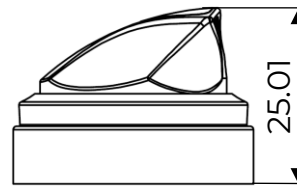
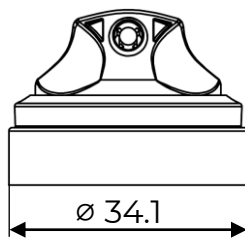

Compatible valves	LI, LIB, Male BOV	Suitable cans	Aluminium Tinplate
Stem Ø	3.3mm, 4mm	Available overcaps	C835 C950 C1000
Available insert	TM40, T130		
Skirt size	6.5mm or 8.2mm		

i Further technical information is available on request

Product packaging

- ✔ 1,500 units per box
- ✔ 20 boxes per euro pallet
- ✔ 30,000 units per pallet

More info:

Visit: www.lindalgroup.com

Email: products@lindalgroup.com

Contact: Your local sales consultant



Your Innovation Partner