

ST970

Insert-less spray head with overcap



An insert-less spray head actuator designed for foam applications in the personal care and pharmaceutical market segments.

Product features:

- ✔ Foam or gel version available
- ✔ Matt finish actuator
- ✔ Overcap available in Matt or Gloss
- ✔ Various skirt heights available
- ✔ Compatible with LINDAL's LI, LIB and male Bag-on-valve (BOV)



More info:

Visit: www.lindalgroup.com

Email: products@lindalgroup.com

Contact: Your local sales consultant

Available configurations

- ✔ Foam or gel version available
- ✔ Compatible with LINDAL's LI, LIB and male Bag-on-valve (BOV)

Technical details – foam version

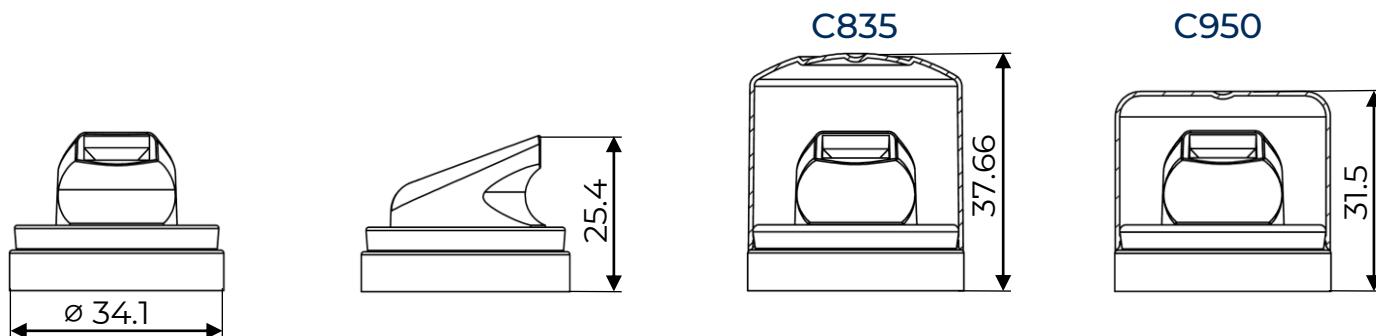

Technical details – gel version

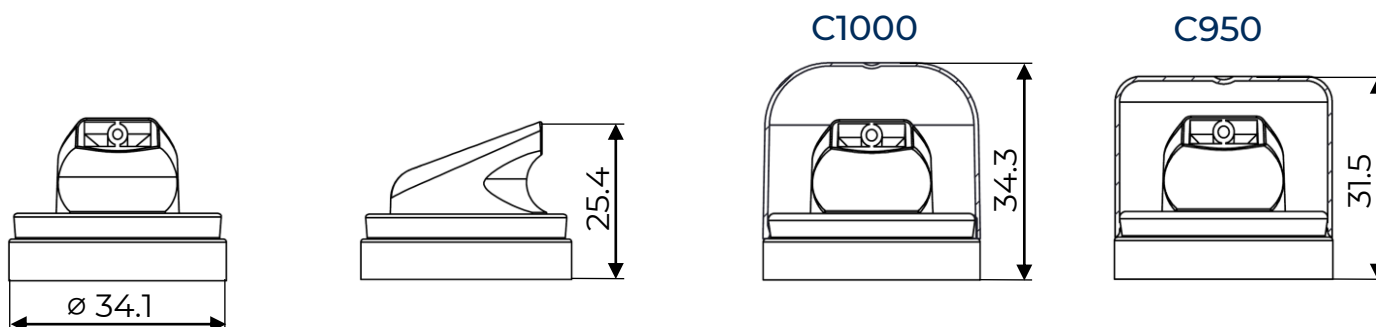

Compatible valves	LI, LIB, Male BOV	Suitable cans	Aluminium Tinplate
Stem Ø	4mm	Available overcaps	C835 (foam only) C950 C1000 (gel only)
Available insert	N/A		
Skirt size	N/A		

i Further technical information is available on request

Product packaging

- ✔ 1,500 / 2,500 units per box
- ✔ 20 / 24 boxes per euro pallet
- ✔ 30,000 / 60,000 units per pallet

More info:

Visit: www.lindalgroup.com

Email: products@lindalgroup.com

Contact: Your local sales consultant



Your Innovation Partner